

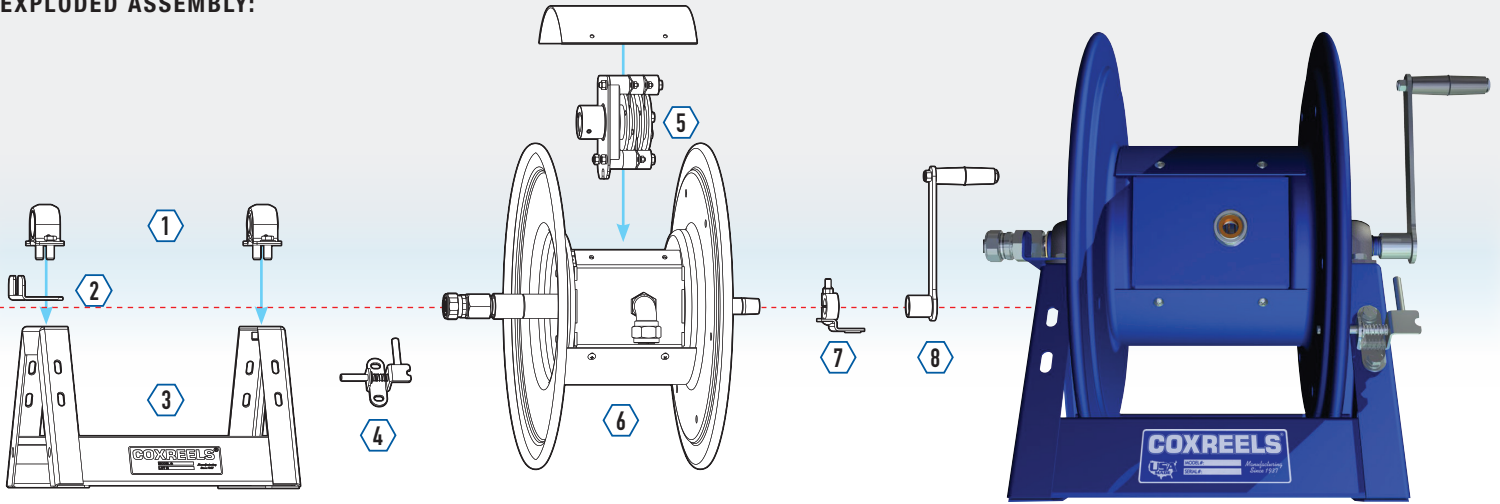

# FEATURE FOCUS HAND CRANK CORD REEL

EXPLODED ASSEMBLY:



## FEATURES & BENEFITS

### STEEL CONSTRUCTION

High-Quality steel construction provides superior strength and durability for heavy-duty applications in commercial and industrial settings.



### POWDER COAT

CPC™ Powder Coat. Long lasting, chip resistant and rust inhibiting CPC™ powder coat finish seals all steel components for maximum corrosion resistance.



### 1 PILLOW BLOCK BEARINGS

Pillow Block Bearings – Sturdy permanently lubricated and self-aligning pillow block bearings for smooth rotation and trouble-free operation.

- Robust lubricated horizontal surface mount bearings on 1-1/2" and 2" hose I.D. models.



### 2 CABLE KEEPER

Integrated anti-rotation cable keeper prevents the 5 foot lead cable from whipping or twisting.

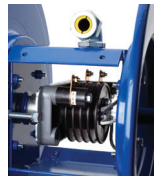

### 5 SLIP RING ASSEMBLY

Drum-located slip ring assembly with easy to access removable panel for simple routine maintenance.

- Available with 30AMP or 45AMP, 600V rated slip ring assembly.



### 6 CNC SPUN DISCS

Heavy duty CNC robotically spun and ribbed discs with rolled edges for greater strength, durability, cable protection and operator safety.



### 3 "A" FRAME

Sturdy one piece, all CNC robotically welded 1/4" steel "A" frame base, not bolted, for superior reel structure and narrow width for convenient installation in restricted spaces.

Mounting Pattern – Mounting pattern located in the steel base for easy reel installation and detachment.



### 7 TENSION BRAKE

Adjustable tension/friction brake adjust the speed of the draw to your desired preference & prevents your reel from "free wheeling"



### 4 LOCKING PIN

Long-handled locking pin secures reel from rotation during storage or transportation



### 8 HAND CRANK

Solid steel direct hand crank with smooth round handle for easy mechanical retraction.

## ACCESSORIES & UPGRADES



ROLLER BRACKETS



PORTABLE HOSE REEL



[www.coxreels.com](http://www.coxreels.com)

800.COX.REEL

P: 480.820.6396

F: 480.820.5132

E: [info@coxreels.com](mailto:info@coxreels.com)

FF-HCCR-01